



# Application of Multiple Regressions to Thermal Error Compensation Technology – Experiment on Workpiece Spindle of Lathe

Ben-Fong Yu<sup>1</sup>, Kang Liu<sup>2</sup>, and Kun-Ying Li<sup>3</sup>, \*

<sup>1</sup>Department of Mechanical Engineering, National Chung Hsing University, Taiwan

<sup>2</sup>Department of Economics, National Chung Cheng University, Taiwan

<sup>3</sup>Department of Machine Tool Technology, Industrial Technology Research Institute, Taiwan

(Received 1 March 2016; Accepted 28 March 2016; Published on line 1 June 2016)

\*Corresponding author email: [likunying@itri.org.tw](mailto:likunying@itri.org.tw)

DOI: [10.5875/ausmt.v6i2.1119](https://doi.org/10.5875/ausmt.v6i2.1119)

**Abstract:** This study focuses on a type of intelligent machine tool – Thermal Error Compensation Technology. Lathes are used to rotate a cylindrical workpiece against fixed tools. The high speed of rotation and frequent changes to the cutting load can result in heat deformation which will reduce the accuracy of the relative position between the tool and the workpiece, thus reducing machining precision. This study measures lathe temperature and thermal errors of a workpiece spindle. Experimental results are subjected to multiple regression analysis to assess the relationship between the heat source and deformation to produce a three axis thermal error model. Additional items from polynomial, interaction and cyclical series are included in the model. Finally, we choose the best thermal error model based on predictive ability. The resulting model has a standard deviation of the forecast error within 5  $\mu\text{m}$ .

**Keywords:** lathe, thermal error model, thermal error compensation, multiple regression, forecast

## Introduction

The rapid development of technologies for electronic circuits, sensors, wireless communications, networks and software, have driven the development of advanced machine tool products. This study focuses on Thermal Errors Compensation (TEC) technology, a hardware approach to integrating sensors into machinery to provide continuous and real-time performance assessment. We collect and analyze large amounts of TEC data, using multidisciplinary integration to create a statistical model for analyzing thermal error compensation, thus effectively optimizing machine performance.

Based on key temperature points, Chen et al. [1-4] used multiple variable nonlinear regression and neural network to create the Thermal Error Model, and verified model reliability by actual cutting. Using a vertical twin-spindle twin-turret lathe, Lo et al. [8] and Yuan et al. [12] applied engineering judgment, correlation analysis and stepwise regression to select the best temperature points.

They then used multiple regression analysis to create several different Thermal Error Models. Lo et al. [8] then used these different models, such as Mallows'  $C_p$ , F test and Coefficient of Multiple Determination ( $R^2=0.982$ ), to identify the most suitable temperature points and the best models, and verified model reliability of model by actual cutting. On a horizontal lathe, Du et al. [5] used 4 temperature points, including water tank, X-axis screw nut, spindle and lathe body, as the independent variables for polynomial regression analysis. The present study focuses on the robustness of the Thermal Error Model, and applies polynomial and interaction regressions (also called interaction effects) to these 4 points to test model accuracy. Lee et al. [7] assessed the accuracy of the Thermal Error Model of CNC machine tools. Although they used Linear Regression Analysis, the Residual Mean Square ( $MSE_p$ ) was used to identify the most suitable temperature points, and they used Multi-Collinearity to improve model accuracy. Yang et al. [11] applied neural networks to the Cerebellar Model Articulation Controller (CMAC) to assess the Thermal Error Model. CMAC is a learning algorithm which can determine the nonlinear and



interactive characteristics of thermal errors to increase model reliability.

In terms of software control compensation, regression analysis and neural networks have been widely used to create the Thermal Error Model. However, both methods require a great deal of experimental data to improve model accuracy, thus some studies have applied multiple regression analysis. In recent years, time sequential data have been added to the analysis of Thermal Errors Compensation Technology, so ARX or ARMX have also been applied to create the Thermal Error Model.

This study seeks to determine the relationship between the heat source of a rotating workpiece spindle and the machine’s thermal errors. The thermal sensors are first placed on the machine to measure the temperature increase while the simultaneously measuring the displacement condition of the workpiece spindle. The acquired data are subjected to statistical analysis to identify the most significant heat source of thermal errors, and thus create a suitable Thermal Errors Model to express the displacement of the workpiece spindle and machine head when the workpiece spindle is heated during rotation.

### Research method

This study applies the regression analysis developed by Neter et al. [9]. The data were obtained through actual tests and subjected to multiple regression analysis. Experimental methods were then applied to verify the results of the Thermal Errors Model. The research scheme is shown in Fig. 1:

#### Regression Model

Regression analysis is a statistical method that uses the relation between two or more quantitative variables to allow one variable to be predicted from the other. It is used to assess the quantitative relationship between one or more independent variables ( $x_n$ ) and a dependent

variable ( $y_i$ ). This study mainly relies on multiple regression analysis in which there are two or more independent variables. A multiple regression can be expressed as the following equation:

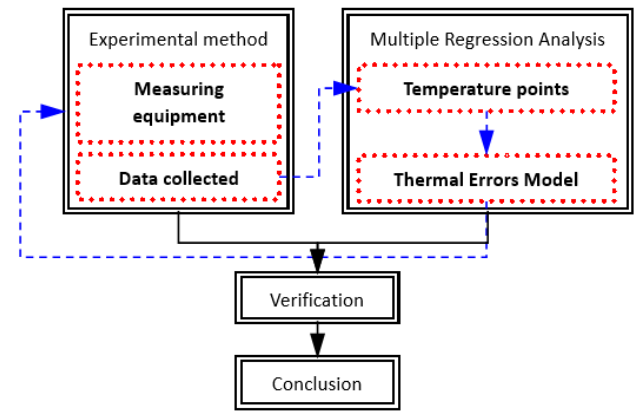

Figure 1. Research scheme.

$$y_i = \beta_{i0} + \beta_{i1}x_{1i} + \beta_{i2}x_{2i} + \dots + \beta_{in}x_{ni} + \epsilon_i \tag{1}$$

where  $\beta_{i0}$  is a constant,  $\beta_{i1} \dots \beta_{in}$  are regression coefficients, and  $\epsilon_i$  is the error term.

Equation (1) is a First Order Linear Model. However, the actual thermal errors cannot be explained by this simple function. Therefore, this study also applies the Polynomial Regression Model and the Interactive regression Model, which are respectively expressed as the following Eqs. (2) and (3), to increase the accuracy of the Thermal Errors Model.

$$y_i = \beta_{i0} + \beta_{i1}x_{1i} + \beta_{i2}x_{2i}^2 + \dots + \beta_{in}x_{ni}^m + \epsilon_i \tag{2}$$

$$y_i = \beta_{i0} + \beta_{i1}x_{1i} + \beta_{i2}x_{2i} + \beta_{i3}x_{1i}x_{2i} + \dots + \beta_{ip}x_{ni}x_{ji} + \epsilon_i \tag{3}$$

where  $n \neq j$

#### Regression Model Test

Once the regression model is set up, we have to determine whether there is a relationship between the dependent variable and the independent variable, and whether the independent variable is sufficient to forecast the dependent variable. The test methods used by this research are as follows:

#### F-test of Regression coefficient

The significance test of regression model tests whether there is a statistical significance between the dependent variable  $y$  and the independent variables  $x_1, x_2, \dots, x_{p-1}$ . The *F-test* is usually used, and the following assumptions are set:

$$H_0 : \beta_1 = \beta_2 = \dots = \beta_n = 0$$

$$H_1 : \beta_k \neq 0 \ (k = 1 \sim p - 1)$$

**Ben-Fong Yu** is a PhD candidate in the department of Mechanical Engineering at National Chung Hsing University, Taiwan. His research interests include mechanical design, mechatronics, and intelligent machine tool. d102061007@mail.nchu.edu.tw

**Kang Liu** is a professor in the Economics Department at National Chung Cheng University, Taiwan. He received his PhD from the department of Agricultural, Environmental and Development Economics at Ohio State University. His current research interests focus on tourism economics, food economics, and applied micro-econometrics. ecdkl@ccu.edu.tw

**Kun-Ying Li** is an engineer of the MTTC (Machine Tools Technology Center at the Industrial Technology Research Institute, He received his MS in Mechanical Engineering from National Chung Cheng University, Taiwan, in 2007. His research interests focus on the thermal equilibrium of machine tools. likunying@itri.org.tw



The following statistical test quantity is applied:

$$F^* = \frac{MSR}{MSE} \quad (4)$$

Set the significance level as  $\alpha$ , and its determination rule is:

$$\begin{aligned} \text{If } F^* &\leq F(1-\alpha; p-1, n-p), \text{ conclude } H_0 \\ \text{If } F^* &> F(1-\alpha; p-1, n-p), \text{ conclude } H_1 \end{aligned}$$

The existence of regression relationship does not necessarily indicate it can produce a correct forecast.

### Coefficient of Multiple Determination ( $R^2$ )

The Coefficient of Multiple Determination is used to explain the goodness of fit of the regression model. It is defined as follows:

$$R^2 = \frac{SSR}{SSTO} = 1 - \frac{SSE}{SSTO} \quad (5)$$

This indicates that, when the independent variables  $x_1, x_2, \dots, x_{p-1}$  are used, total variation of  $y$  forecast is decreased. The relationship of  $R^2$  is  $0 \leq R^2 \leq 1$ . Generally speaking, when  $R^2=0$ , the dependent variable and the independent variable do not have a linear relationship. When  $R^2 \neq 0$ , the dependent variable can be explained by the independent variable.

### Adjusted Coefficient of Multiple Determination ( $R_a^2$ )

In the regression model,  $R^2$  will be used to describe the explanatory power of whole model. But  $R^2$  will be influenced by the sample size to result in overvaluation. When the samples size is smaller, the overvaluation problem will occur easily. Therefore, to obtain a more accurate evaluation, after adjustment one must adopt the Coefficient of Multiple Determination, defined as  $R_a^2$ :

$$R_a^2 = 1 - \left( \frac{n-1}{n-p} \right) \frac{SSE}{SSTO}$$

After applying the Degree of Freedom ( $df$ ), we can prevent overvaluing the explanatory power of the whole regression model due to the smaller sample size. That is, when another independent variable is introduced in the model,  $R_a^2$  will be smaller, thus the introduced independent variable has no significant effect on the model.

### Selection of Independent Variable

Most regression models can have several independent variables. However, excessive independent variables (i.e., temperature points) will increase waste as sufficient hardware is required to capture and calculate

the data. In addition, surplus variables contribute little to improving forecasting accuracy, reduce the model's descriptive capacity, and increase the likelihood of calculation error. Thus, we seek to use fewer independent variables to obtain a better regression model while minimizing costs.

This study adopts the Confirmation Assignment and the Stepwise Regression Procedures of the sequential search method to select independent variables (temperature points). We then use the regression model created using the most suitable independent variables to conduct the test specified in previous section, and finally validate the regression model through the testing.

## Experimental Setup

Temperature and displacement are the key Thermal Errors Compensation Technology parameters used here. A total of 15 thermal sensors were used to measure temperature differences (Fig. 2). T1 is room temperature, while T2-T6 and T9 are on the headstock, T7-T8 is on the bed, T10-T11 are on the feed system Z-axis, T12-T13 are on the feed system X-axis, and T14-T15 are on the feed system Y-axis. In addition, 5 eddy current displacement meters are used to measure thermal errors of the workpiece spindle, with two each in the X and Y directions and one in the Z direction (as shown in Fig. 3).

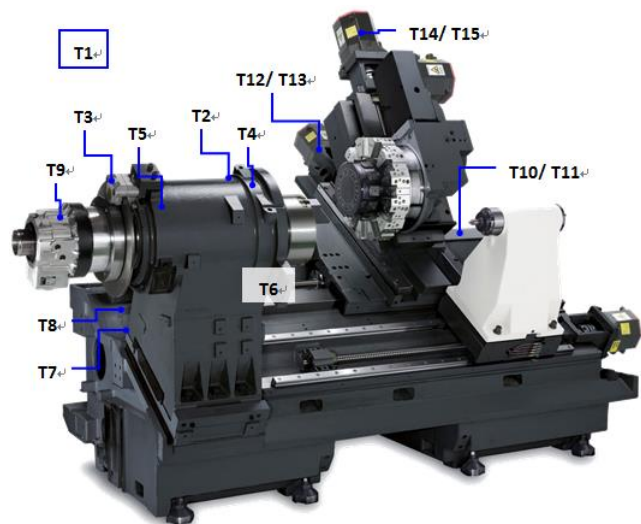

Figure 2. Layout with thermal sensors.

We first use a First Order Linear Model to describe the definition between the experimental data and the variables. According to the 15 temperature difference data sources and the 5 thermal errors, the correspondence of every variable is shown in Table 1, where  $y_1 \sim y_5$  represent the 5 thermal errors, and  $x_1 \sim x_{15}$  represent the 15 temperature difference data sources. We substitute the data in Table 1 into Eq. 1 to obtain

$$y_i = \beta_{i0} + \beta_{i1}x_{1i} + \dots + \beta_{im}x_{mi} + \varepsilon_i$$

$$= \beta_{i0} + \sum_{n=1}^{15} \beta_{in}x_{ni} + \varepsilon_i \quad (7)$$

where  $i=1\sim5, n=1\sim15$ .

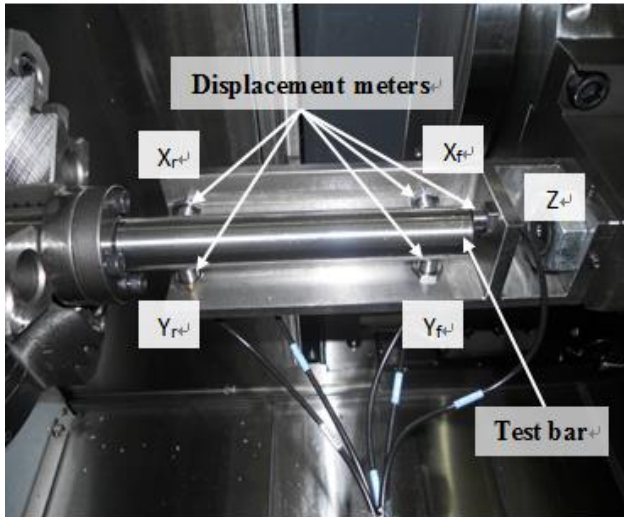

Figure 3. Measuring equipment.

Table 1. Variable correspondence.

| Dependent variable     | Independent variable                           | Regression coefficients                      |
|------------------------|------------------------------------------------|----------------------------------------------|
| $y_i$                  | $X_1, X_2, \dots, X_{15}$                      | $\beta_{i0}, \beta_{i1}, \dots, \beta_{i15}$ |
| $y_1 \quad \Delta Z$   | $\Delta T_1, \Delta T_2, \dots, \Delta T_{15}$ | $B_{1,0}, \beta_{1,1}, \dots, \beta_{1,15}$  |
| $y_2 \quad \Delta X_r$ | $\Delta T_1, \Delta T_2, \dots, \Delta T_{15}$ | $B_{2,0}, \beta_{2,1}, \dots, \beta_{2,15}$  |
| $y_3 \quad \Delta X_f$ | $\Delta T_1, \Delta T_2, \dots, \Delta T_{15}$ | $B_{3,0}, \beta_{3,1}, \dots, \beta_{3,15}$  |
| $y_4 \quad \Delta Y_r$ | $\Delta T_1, \Delta T_2, \dots, \Delta T_{15}$ | $B_{4,0}, \beta_{4,1}, \dots, \beta_{4,15}$  |
| $y_5 \quad \Delta Y_f$ | $\Delta T_1, \Delta T_2, \dots, \Delta T_{15}$ | $B_{5,0}, \beta_{5,1}, \dots, \beta_{5,15}$  |

### Experimental Condition

Table 2 summarizes the experimental conditions. A constant rotation speed is used to acquire the temperature and displacement data, and the rotation speed varies between groups.

### Experimental Results

Experimental data are processed using Excel and SPSS, and the results of Group B are summarized as follows. Figure 4 shows the temperature differences (in °C) of Group B at the 15 sensor locations (i.e.,  $\Delta T_1, \Delta T_2 \dots \Delta T_{15}$ ). Figure 5 shows the thermal errors (in  $\mu\text{m}$ ) of the spindle in the X, Y and Z directions as  $\Delta X_r$  (red),  $\Delta Y_r$  (cyan) and  $\Delta Z$  (blue). The results of each group are summarized. Figure 6 shows the whole temperature differences. Figure 7 shows all the thermal errors. The main purpose is to observe their repeatability.

Table 2. Variable correspondence.

| Group | Definition            | Experimental condition                                                                                                                                                                       |
|-------|-----------------------|----------------------------------------------------------------------------------------------------------------------------------------------------------------------------------------------|
| A     | Constant rotary speed | 1. Operate continuously at 1200 rpm for 12hr<br>2. Take data for 12hr each time; 5 times                                                                                                     |
| B     | Constant rotary speed | 1. Operate continuously at 2000 rpm for 10hr<br>2. Take data for 10hr each time; 5 times                                                                                                     |
| C     | Constant rotary speed | 1. Operate continuously at 3000 rpm for 10hr<br>2. Take data for 10hr each time; 5 times                                                                                                     |
| D     | Variable rotary speed | 1. Operate at 1200 rpm for 50 min/shut down 20 min, operate at 2000 rpm for 50 min/shut down 20 min, operate at 3000 rpm for 50 min, 3hr in total<br>2. Take data for 3hr each time; 8 times |
| E     | Variable rotary speed | Integrate the data of Experiments A, B and C for the subsequent substitution of regression analysis because they represent the results at different rotation speeds.                         |

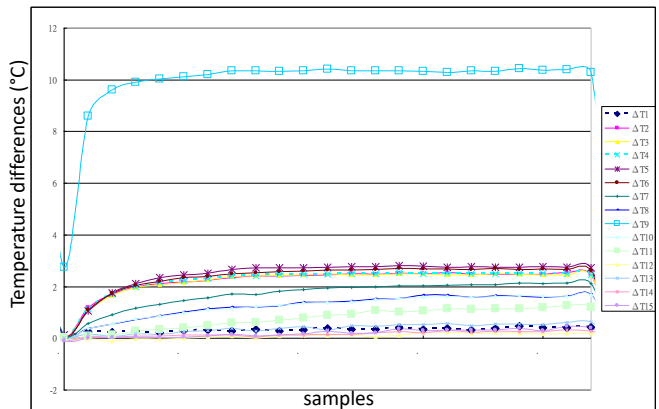

Figure 4. Temperature differences of Group B.

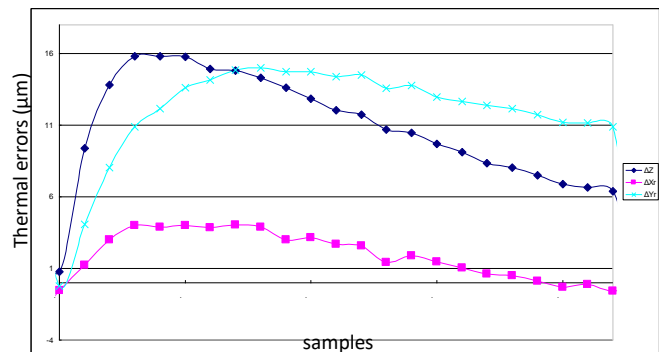

Figure 5. Thermal errors of Group B.

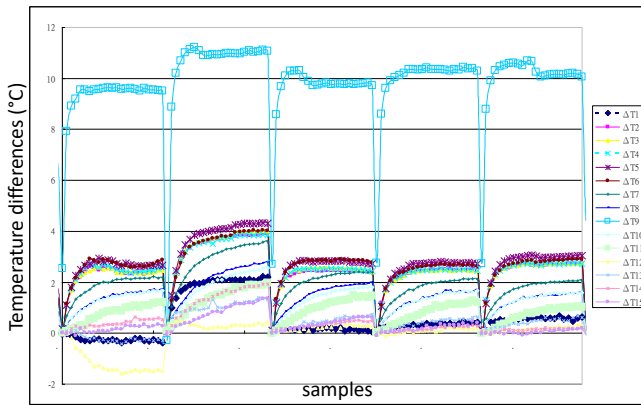

Figure 6. Total temperature differences of Group B.

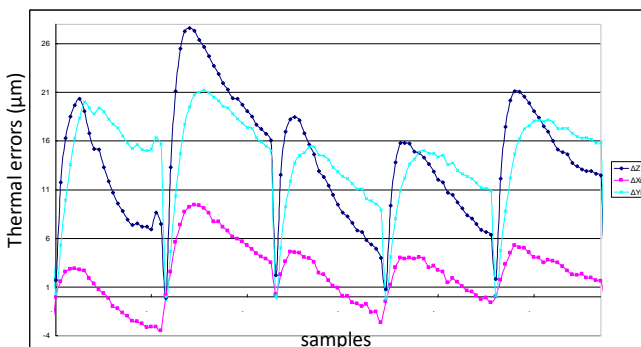

Figure 7. Total thermal errors of Group B.

### Testing for Independent Variable

In this section, the Confirmation Assignment and the Stepwise Regression Procedure for a sequential search method are used to select the independent variables (i.e., temperature points), where the judgment criteria are as follows: (1)  $R_p^2$  is greater than 0.9, (2) the statistical quantity of  $F^*$  test is significant, and (3)  $MSE_p$  is relatively smaller. We compare the regression analysis results of each group to determine the most suitable independent variables and the best regression model. This study seeks to use the fewest temperature points to produce a precise thermal error forecast. The most suitable independent variables are (1)  $\Delta X_r$ : *Speed*,  $\Delta T_1$ ,  $\Delta T_4$ ,  $\Delta T_{11}$  of Group E, (2)  $\Delta Y_r$ : *Speed*,  $\Delta T_1$ ,  $\Delta T_4$ ,  $\Delta T_{11}$  of Group E, and (3)  $\Delta Z$ : *Speed*,  $\Delta T_1$ ,  $\Delta T_4$ ,  $\Delta T_{11}$  of Group E. A regression analysis is then conducted for the most suitable independent variables of each thermal error to obtain the regression coefficients. We substitute these into Eq. 7 to obtain the regression model of each deviation, where Eqs. 8~10 respectively obtain  $\Delta X_r$ ,  $\Delta Y_r$  and  $\Delta Z$ .

$$\Delta X_r = -4.198 + 0.907 \text{ Speed} + 2.462\Delta T_1 + 3.49\Delta T_4 - 6.565\Delta T_{11} \quad (8)$$

$$\Delta Y_r = -0.369 - 2.583 \text{ Speed} - 2.423\Delta T_1 + 9.791\Delta T_4 - 4.743\Delta T_{11} \quad (9)$$

$$\Delta Z = -2.156 + 1.138 \text{ Speed} + 2.75\Delta T_1 + 9.815\Delta T_4 - 14.106\Delta T_{11} \quad (10)$$

### Testing for Regression Model

Most previous attempts to obtain suitable independent variables to create a regression model did not go beyond testing the independent variables, using the resulting models to complete the Thermal Errors Compensation Technology. However, this study seeks to produce an optimal regression model with a robust Thermal Errors Compensation effect. In their literature survey, Du et al. [5] used 4 temperature points to test the polynomial and interaction regressions to verify model accuracy. Lee et al. [7] used linear regression analysis to create the model, and discussed the issue of Multi-Collinearity.

The most suitable independent variables (i.e., *Speed*,  $\Delta T_1$ ,  $\Delta T_4$ ,  $\Delta T_{11}$ ) obtained are used in the Polynomial Regression, Interaction Effects and Combination of Cases (i.e., the combination of Polynomial Regression and Interaction Effects) for the regression analysis. Because this study seeks to create a robust Thermal Errors Model, it focuses on the predictability, judgement criterion of the regression model and  $R_p^2$  related to goodness of fit and  $F^*$  related to significance. Among them, the deviation  $\Delta X_r$  does not have a relationship between Polynomial and Interaction Effects. The deviation  $\Delta Y_r$  has such a relationship, while the deviation  $\Delta Z$  only has a relationship with Polynomial Effects. No independent variable in  $\Delta Z$  does has a relationship with Interaction Effects. Therefore, the most suitable independent variables for the regression model are redefined as (1)  $\Delta X_r$ : *Speed*,  $\Delta T_1$ ,  $\Delta T_4$ ,  $\Delta T_{11}$ , (2)  $\Delta Y_r$ : *Speed*,  $\Delta T_1$ ,  $\Delta T_4$ ,  $\Delta T_{11}$ ,  $\Delta T_{11}^2$ ,  $\Delta T_4$ ,  $\Delta T_{11}$ , (3)  $\Delta Z$ :  $\Delta T_1^2$ ,  $\Delta T_4$ ,  $\Delta T_{11}$ . We substitute the most suitable independent variables into Eq. 7 to obtain the best regression model of each deviation, where Eqs. 11~13 respectively obtain  $\Delta X_r$ ,  $\Delta Y_r$  and  $\Delta Z$ . Finally, each confirmed regression model (Thermal Errors Model) is introduced into the thermal errors compensation system, and verified by the experimental method.

$$\Delta X_r = -4.198 + 0.907 \text{ Speed} + 2.462\Delta T_1 + 3.49\Delta T_4 - 6.565\Delta T_{11} \quad (11)$$

$$\Delta Y_r = -0.24 - 1.331 \text{ Speed} - 2.074\Delta T_1 + 6.924\Delta T_4 - 0.426\Delta T_{11} - 5.279\Delta T_{11}^2 + 2.39\Delta T_4\Delta T_{11} \quad (12)$$

$$\Delta Z = -2.414 + 1.107\Delta T_1^2 + 11.158\Delta T_4 - 15.137\Delta T_{11} \quad (13)$$

### Analysis for Predictability of the Model

The predictability of the Thermal Errors Model will directly influence the result of the Thermal Errors Compensation. If model predictability is high, the compensation will be accurate, and will help increase of processing precision. On the other hand, if model predictability is low, the compensation will not be accurate, and thus will not be helpful for the Thermal

Errors Compensation Technology. However, the forecast will contain errors, so the main purpose of this section is to describe how to measure these errors to better assess the accuracy of model predictions.

Pindyck et al. [10] and Hanke et al. [6] provide extensive forecast descriptions. The Thermal Errors Model used in the present study produces quantitative forecasts. As for the single direction model, this study uses the difference of actual value and forecast value to define the residual or forecast error, as shown in Eq. 14.

$$\varepsilon_t = y_t - \hat{y}_t \tag{14}$$

where  $\varepsilon_t$  is the forecast error (also called the residual),  $y_t$  is the actual value, and  $\hat{y}_t$  is the forecast value. Based on the literature survey, we can use the following three evaluation criteria to forecast the error.

**Absolute Error Measures**

Absolute Error Measures is a method used to test the correctness or significance of forecast errors. For both accumulated and mean errors, the absolute value or square value must be taken for each forecast error to prevent deriving the wrong conclusion due to the balance of positive and negative signs. This study uses the Mean Absolute Deviation (*MAD*), Mean Square Error (*MSE*) and Root Mean Square Error (*RMSE*).

$$MAD = \frac{1}{n} \sum_{t=1}^n |y_t - \hat{y}_t| \tag{15}$$

$$MSE = \frac{1}{n} \sum_{t=1}^n (y_t - \hat{y}_t)^2 \tag{16}$$

$$RMSE = \sqrt{\frac{1}{n} \sum_{t=1}^n (y_t - \hat{y}_t)^2} \tag{17}$$

where  $n$  is number of samples.

**Relative Error Measures**

Under certain conditions, the forecast value will deviate from the range of the actual value, which has more reference value than the absolute value. This will reveal the forecast error as a percentage called the Relative Error Measure. This study uses the Mean Absolute Percentage Error (*MAPE*) and Mean Percentage Error (*MPE*).

$$MAPE = \frac{1}{n} \sum_{t=1}^n \left| \frac{y_t - \hat{y}_t}{y_t} \right| \tag{18}$$

$$MPE = \frac{1}{n} \sum_{t=1}^n \frac{(y_t - \hat{y}_t)}{y_t} \tag{19}$$

where  $n$  is the number of samples.

**Theil’s Inequality Coefficient**

Theil’s Inequality Coefficient ( $U$ ) can be used to

measure forecast results (as shown in Eq. 15). If  $U$  approaches 0, it means the actual and forecast values are consistent, and model predictability is high. If  $U$  approaches 1, it means the actual and forecast values are inconsistent, and model predictability is low.

$$U = \frac{\sqrt{\frac{1}{n} \sum_{t=1}^n (y_t - \hat{y}_t)^2}}{\sqrt{\frac{1}{n} \sum_{t=1}^n (y_t)^2 + \frac{1}{n} \sum_{t=1}^n (\hat{y}_t)^2}} \tag{20}$$

where  $n$  is the number of samples.

To judge the predictability of two models specified in Section – “Regression model test”, we use the abovementioned six measurement criteria to analyze predictability, with results summarized in Table 3.

Table 3. Regression model test results.

| Method | $\Delta X_r$ | $\Delta Y_r$ | $\Delta Z$ |
|--------|--------------|--------------|------------|
| MAD    | 0.959        | 1.014        | 1.206      |
| MSE    | 1.418        | 1.684        | 2.449      |
| RMSE   | 1.191        | 1.298        | 1.565      |
| MAPE   | 183.67%      | 17.53%       | 16.73%     |
| MPE    | 94.51%       | 5.77%        | -1.92%     |
| $U$    | 0.142        | 0.042        | 0.051      |

The absolute error of  $\Delta X_r$  in Thermal Errors Model is smaller than that of  $\Delta Y_r$  and  $\Delta Z$ . But the relative error and the Theil’s Inequality Coefficient are much larger than those of  $\Delta Y_r$  and  $\Delta Z$ , and *MAPE* is as high as 183.67%. Thus the accuracy of  $\Delta X_r$  in the Thermal Errors Model is high, but the model has poor forecast accuracy, meaning the distribution range of the forecast error is larger. However, the  $U$  value is 0.142, which means that it has certain level of forecast accuracy. The selection of  $\Delta Y_r$ , mainly in the Thermal Errors Model 2, the absolute error, relative error and Theil’s Inequality Coefficient are smaller, meaning model accuracy is high and the forecast precision is good. The *MPE* is positive, which means the forecast value is smaller than the actual value. The absolute error, relative error and Theil’s Inequality Coefficient for models 1 and 2 of  $\Delta Z$  are very close, with respective *MAPE* values of 20.47% and 16.73%. So the accuracy of the two models is high, and the forecast precision is good. The *MPE* value is negative, which means the forecast value is larger than the actual value. Thus Thermal Errors Model 1 is selected to obtain  $\Delta Z$ .

**Conclusions**

The selection of  $\Delta X_r$  in the Thermal Errors Model is presented in Eq. 11. The selection of  $\Delta Y_r$  in the Thermal

Errors Model is presented in Eq. 12. The selection of  $\Delta Z$  in the Thermal Errors Model is presented in Eq. 10. We then compare and analyze the measurement data of Groups A, B, C and D. First, we use the test results of Group A, B, C and D as the actual values, and respectively plot them with the forecast values in Figs. 8~11. The horizontal axis is time, and the vertical axis is the deviation (unit:  $\mu\text{m}$ ).  $\Delta X_r$ ,  $\Delta Y_r$  and  $\Delta Z_r$  represent the actual values measured, and  $X_1$ ,  $Y_1$  and  $Z_1$  represent the forecast values calculated from the Thermal Errors Model ( $\Delta X_r$ ,  $\Delta Y_r$  and  $\Delta Z_r$ ). The goodness of fit for the actual and forecast values of  $\Delta X_r$ ,  $\Delta Y_r$  and  $\Delta Z_r$  in the Thermal Errors Model is high. Under a constant rotation speed (Groups A, B and C), the forecast values and the actual values alternate.

Under a variable rotary speed (Group D), the forecast values are smaller than the actual values. In Group A, the forecast values of  $X_1$  and  $Z_1$  fluctuate. However, when the rotary speed is increased (Groups B and C), the fluctuation for the forecast values of  $X_1$ ,  $Y_1$  and  $Z_1$  stabilizes. As for Group D, the forecast values of  $Y_1$  are smoother, while the forecast values of  $X_1$  and  $Z_1$  increase significantly. However, when the rotation speed is increased, the model's goodness of fit is not significantly improved.

Thermal Errors Compensation Technology consists of four steps: data collection, data analysis, modeling and system compensation. The present study differs from previous efforts in terms of the procedures for determining criteria for the Thermal Errors Model. The acquired data are used to create the model and statistical methods are used to test the model's robustness. This study mainly relies on multiple regression analysis. According to the judgement criteria, the proposed approach selects the most suitable independent variables and the best model. The polynomial, multiplication and lag items of the independent variables are added continuously to the models to obtain the test models. Finally, we select the Thermal Errors Model which produces the best result predictability.

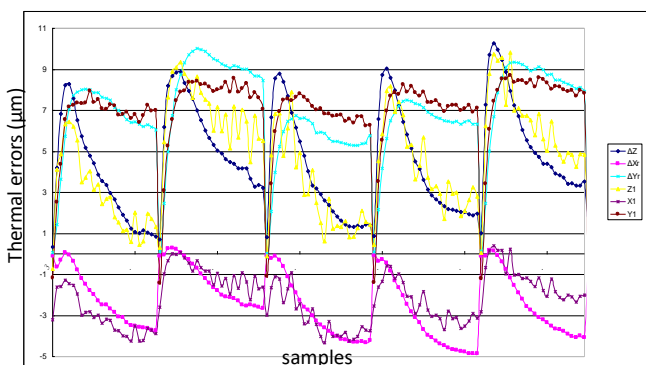

Figure 8. Actual and forecast value of Group A.

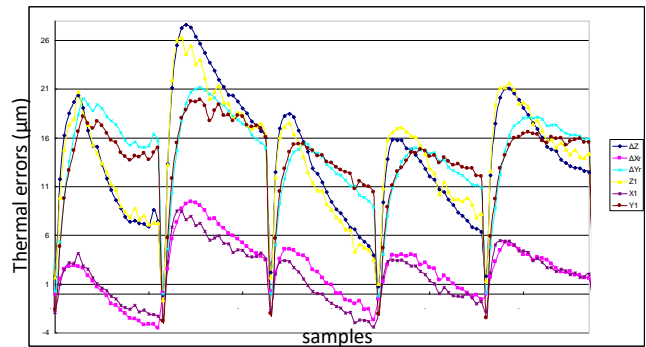

Figure 9. Actual and forecast value of Group B.

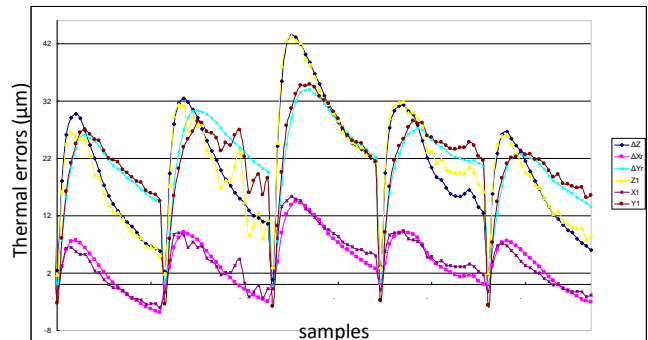

Figure 10. Actual and forecast value of Group C.

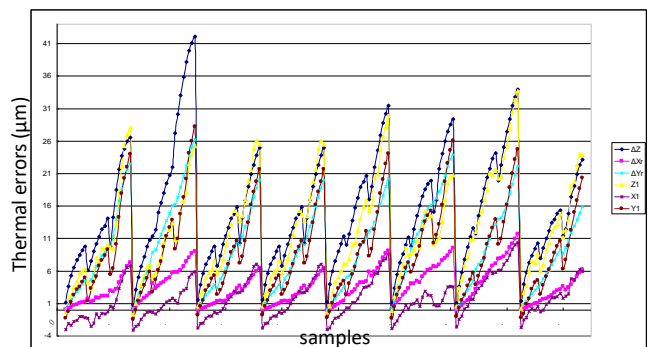

Figure 11. Actual and forecast value of Group D.

## References

- [1] J.-S. Chen, "A Study of Thermally Induced Machine Tool Errors in Real Cutting Conditions," *International Journal of Machine Tools Manufacture*, vol. 36, no. 12, pp. 1401-1411, 1996.  
doi: [10.1016/0890-6955\(95\)00096-8](https://doi.org/10.1016/0890-6955(95)00096-8)
- [2] J.-S. Chen, "Fast Calibration and Modeling of Thermally Induced Machine Tool Errors in Real Machining," *International Journal of Machine Tools Manufacture*, vol. 37, no.2, pp. 159-169, 1997.  
doi: [10.1016/S0890-6955\(96\)00042-9](https://doi.org/10.1016/S0890-6955(96)00042-9)
- [3] J.-S. Chen and G. Chiou, "Quick Testing and Modeling of Thermally-Induced Errors of CNC Machine Tools," *International Journal of Machine Tools Manufacture*, vol. 35, no. 7, pp. 1063-1074, 1995.  
doi: [10.1016/0890-6955\(94\)00101-0](https://doi.org/10.1016/0890-6955(94)00101-0)
- [4] J.-S. Chen, J.-X. Yuan, J. Ni, and S.-M. Wu, "Real-Time Compensation for Time-Variant Volumetric Errors On

- a Machining Center,” *Transactions of ASME, Journal of Engineering for Industry*, vol. 115, no. 4, pp. 472-479, 1993.  
doi: [10.1115/1.2901792](https://doi.org/10.1115/1.2901792)
- [5] Z.-C. Du, J.-G. Yang, Z.-Q. Yao, and B.-Y. Xue, “Modeling approach of regression orthogonal experiment design for the thermal error compensation of a CNC turning center,” *Journal of materials Processing Technology*, vol. 129, no.1-3, pp. 619-623, 2002.  
doi: [10.1016/S0924-0136\(02\)00668-4](https://doi.org/10.1016/S0924-0136(02)00668-4)
- [6] J. E. Hanke and D. W. Wichern, *Business Forecasting, 9th*. Upper Saddle River, New Jersey, USA: Pearson Education, 2009.
- [7] J.-H. Lee and S.-H. Yang, “Statistical optimization and assessment of a thermal error model for CNC machine tools,” *International Journal of Machine Tools & Manufacture*, vol.42, no. 1, pp. 147-155, 2002.  
doi: [10.1016/S0890-6955\(01\)00110-9](https://doi.org/10.1016/S0890-6955(01)00110-9)
- [8] C.-H. Lo, J. Yuan, and J. Ni, “Optimal Temperature Variable Selection by Grouping Approach for Thermal Error Modeling and Compensation,” *International Journal of Machine Tools & Manufacture*, vol. 39, no. 9, pp. 1383-1396, 1999.  
doi: [10.1016/S0890-6955\(99\)00009-7](https://doi.org/10.1016/S0890-6955(99)00009-7)
- [9] J. Neter, M. H. Kutner, C. J. Nachtsheim, and W. Wasserman, *Applied Linear Regression Models*. Burr Ridge, IL, USA: Richard D. Irwin, 1996.
- [10] R. S. Pindyck and D. L. Rubinfeld, *Econometric Models and Economic Forecasts, 4<sup>th</sup>*. Boston, MA, USA: Irwin/McGraw-Hill, 1998.
- [11] S. Yang, J. Yuan, and J. Ni, “The Improvement of Thermal Error Modeling and Compensation on Machine Tools by CMAC Neural Network,” *International Journal of Machine Tools & Manufacture*, vol. 35, no. 7, pp. 1063-1074, 1995.  
doi: [10.1016/0890-6955\(95\)00040-2](https://doi.org/10.1016/0890-6955(95)00040-2)
- [12] J. Yuan and J. Ni, “The Real-Time Error Compensation Technique for CNC Machining Systems,” *Mechatronics*, vol. 8,no. 4, pp. 359-380, 1998.  
doi: [10.1016/S0957-4158\(97\)00062-7](https://doi.org/10.1016/S0957-4158(97)00062-7)

